



# LEAKPROOF CONNECTIONS

Reporting the news, progress and other happenings at CPV Manufacturing, Inc.

Spring 2006

## CPV brings new design to the internet.

For close to a century CPV has been listening to our customers and responding to their needs. This has led to our long list of innovative new products. Developing relevant solutions for customer needs is the surest way to market success.

Now it's time for the CPV customer-driven dynamic to be put to work on our website, [www.cpvvmfg.com](http://www.cpvvmfg.com). For years we have had a perfectly good, hard working website that helped our customers find the right CPV valves and fittings. Things are different these days and customers often use the Internet as their primary source of product and service information. That's why you'll find several major improvements to our new site.

### 1. Search engine optimization

A major goal for the new website is making it easy to find. The new website design uses and/or embeds all the key words used by people searching for information about CPV high-pressure valves and fittings. You'll find them clustered on the new home page, and other new lead pages. Activating CPV's presence within the search engines is critical to reaching out to new customers. Once on site, CPV quality, design, function, and reliability will close the sale.

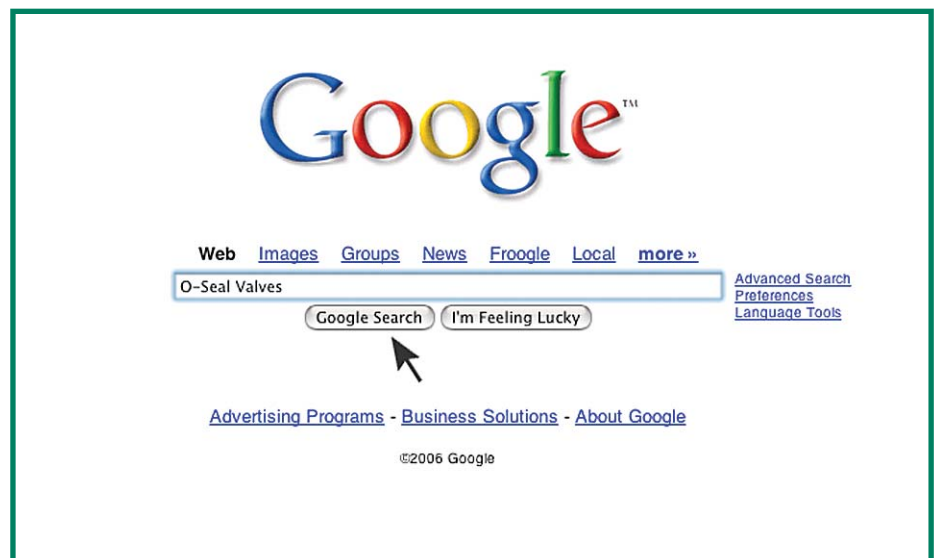

## 2. Improved look and navigation

CPV's new site also brings the design and content up to date. Many of the pages have both a new look and a new presentation of CPV products and services. In addition, there are now a number of useful pull down menus to speed visitors' progress to their desired destination. Plus there is a new site map to expedite finding the product categories of interest.

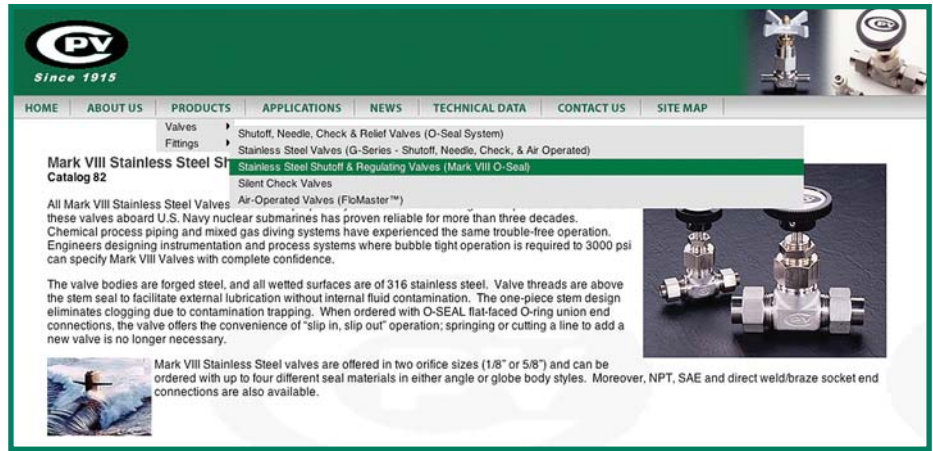

## 3. New technical data section

The new CPV website offers a section with technical data including:

- Engineering Data
- Tools & Maintenance
- Information Sheets – To specify customer requirements
- Product Torque Values
- Product Weights Data (lbs)
- Valve Assembly/Disassembly Instructions

This will make it easier for CPV customers to specify and exchange engineering information.

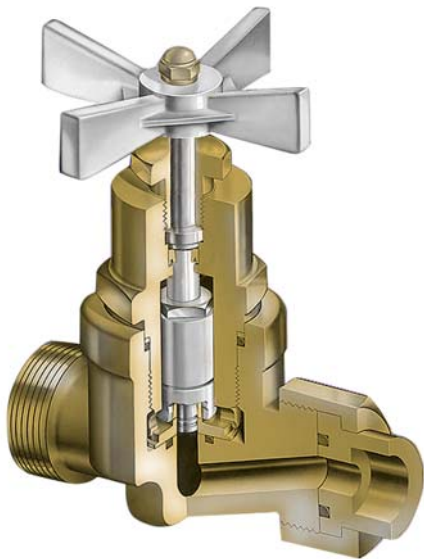
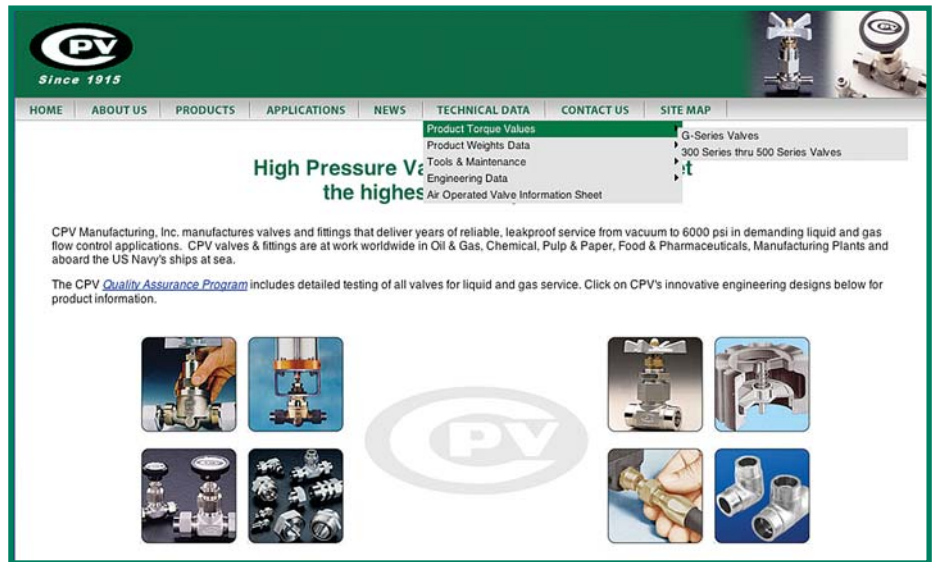

### How about some razzle dazzle?

Absolutely! We want all of our customers and potential customers to check out the new website even if they don't have any valve or fitting needs at the moment. So we are designing a contest that will not only bring visitors to the site, but get them to explore the information pages. Keep your eye out for details on this program during the next month.

### About CPV

CPV has been a leading manufacturer of valves and fittings since 1915. The company's innovative designs are well suited to standard applications as well as highly specific requirements. For more information or technical literature on CPV Valves & Fittings contact:

Charles J. Horter  
Sales & Marketing Manager  
CPV Manufacturing, Inc.  
851 Preston Street  
Philadelphia, PA 19104-1598  
Phone: (215) 386-6508, Ext. 244  
E-mail: C\_horter@cpvmfg.com



### CPV Manufacturing, Inc.

851 Preston St., Philadelphia, PA 19104-1598 Phone: (215) 386-6508 Toll free: (888) 386-2211  
Fax: (215) 387-9043 Website: www.cpvmfg.com