

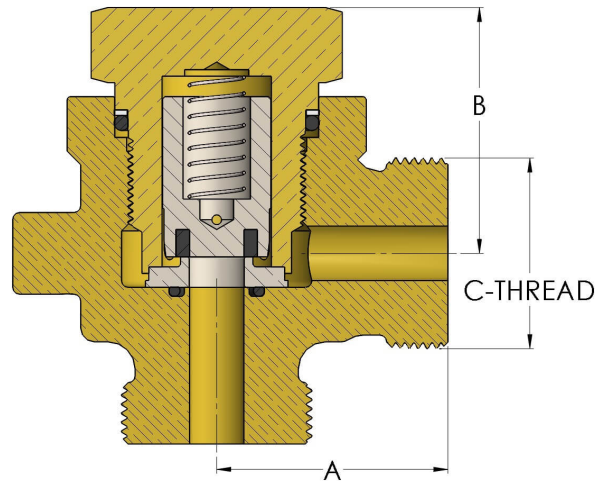

Product Category  
Product Line  
Part Description

681-6  
O-SEAL® Check Valves (600 Series)  
1.25" Angle Check Valve with O-SEAL® Ends



## DIMENSIONS

Port Dia.	1
A	3.250
B	3.81
C	3.00
C-THREAD	2.750"-12UN

## GENERAL

Pressure Rating	6000 PSI
Temperature Range	-15°F to 275°F (-26°C to 135°C)
Standard Soft Goods	[-C] Viton® O-Rings
Cartridge Type	Check
Connection Type	O-SEAL® Union Thread
Connection Size	1.25"
Body Material	Nickel Aluminum Bronze, ASTM B148, UNS C95800
Bonnet Material	Nickel Aluminum Bronze, ASTM B148, UNS C95800

## OPTIONS

<b>Port &amp; Vent Options</b>	[-PA] Port Above Seat (1/4" NPT), [-PB] Port Below Seat (1/4" NPT), [-VA] Vent Above Seat (1/2"-13 SAE), [-VB] Vent Below Seat (1/2"-13 SAE),
<b>Optional Soft Goods</b>	[-B] Polyurethane® Packing and Buna-N O-Rings, [-C] Viton® Packing & O-Rings, [-D] EPDM Packing & O-Rings

cpvmfg.com | 484.731.4010

The complete catalog contents must be reviewed to ensure that the system designer and user make a safe product selection. When selecting products, the total system design must be considered to ensure safe, trouble-free performance. Function, material compatibility, adequate ratings, proper installation, operation, and maintenance are the responsibilities of the system designer and user. Caution: Do not mix or interchange valve components with those of other manufacturers.